



Designation: F482 – 09 (Reapproved 2020)

Standard Practice for Corrosion of Aircraft Metals by Total Immersion in Maintenance Chemicals¹

This standard is issued under the fixed designation F482; the number immediately following the designation indicates the year of original adoption or, in the case of revision, the year of last revision. A number in parentheses indicates the year of last reapproval. A superscript epsilon (ϵ) indicates an editorial change since the last revision or reapproval.

1. Scope

1.1 This practice covers the determination of the corrosiveness of tank-type aircraft maintenance chemicals on aircraft metals and the corrodibility of metals in these maintenance chemicals with time. The determination is made under conditions of total immersion by a combination of weight change measurements and visual qualitative determinations of change.

1.2 The values stated in SI units are to be regarded as the standard. The values given in parentheses are for information only.

1.3 *This standard does not purport to address all of the safety concerns, if any, associated with its use. It is the responsibility of the user of this standard to establish appropriate safety, health, and environmental practices and determine the applicability of regulatory limitations prior to use.* For specific precautions, see Section 6.

1.4 *This international standard was developed in accordance with internationally recognized principles on standardization established in the Decision on Principles for the Development of International Standards, Guides and Recommendations issued by the World Trade Organization Technical Barriers to Trade (TBT) Committee.*

2. Referenced Documents

2.1 *ASTM Standards:*²

D235 Specification for Mineral Spirits (Petroleum Spirits) (Hydrocarbon Dry Cleaning Solvent)

D329 Specification for Acetone

D1193 Specification for Reagent Water

E1 Specification for ASTM Liquid-in-Glass Thermometers

¹ This practice is under the jurisdiction of ASTM Committee F07 on Aerospace and Aircraft and is the direct responsibility of Subcommittee F07.07 on Qualification Testing of Aircraft Cleaning Materials.

Current edition approved Nov. 1, 2020. Published December 2020. Originally published in 1977. Last previous edition approved in 2014 as F482 – 09(2014). DOI: 10.1520/F0482-09R20.

² For referenced ASTM standards, visit the ASTM website, www.astm.org, or contact ASTM Customer Service at service@astm.org. For *Annual Book of ASTM Standards* volume information, refer to the standard's Document Summary page on the ASTM website.

3. Significance and Use

3.1 This practice not only provides information on the accumulated effects of corrosion at specific time periods under a given set of conditions, but also provides information on the initial rate of corrosion of virgin metal, the corrosion rate of metal per unit time after long exposure, and the initial corrosion rate of virgin metal after long exposure of the corroding fluid to metal. The test also provides a means of determining the direction corrosion will take with time, although causes for increase or decrease in the corrosiveness and corrodibility of media and metal (such as passive film formation or destruction, depletion of corrosive contaminate, and so forth) as a function of time are not given.

4. Apparatus

4.1 *Wide-Mouth Glass Jar or Flask* of suitable sizes (3000 to 4000 mL), capable of accommodating a reflux condenser, a thermometer, and a specimen support system. **Fig. 1** shows a typical arrangement, but any array meeting the provisions of 4.2 – 4.5 is acceptable.

4.1.1 If agitation is required, use an apparatus capable of accepting a stirring mechanism, such as a magnetic stirrer or impeller. Choose the glass jar or flask such that the specimens will remain fully immersed in a vertical position during the test, and the ratio of area of immersed metal to volume of solution will be in accordance with 9.1.

4.2 *Specimen-Supporting Device*—a glass or fluorocarbon plastic supporting system designed to keep the specimen fully immersed while assuring free contact with the corroding solution, and designed to physically isolate the specimens from each other.

4.3 *Condenser*—a glass reflux condenser of the water-cooled type, having a condenser jacket 200 to 300 mm in length.

4.4 *Constant-Temperature Device*—Use any suitable regulated heating device (mantle, hot plate, or bath) to maintain the solution at the required temperature.

4.5 *Thermometer*—an ASTM 75-mm (3-in.) immersion thermometer having a range from –18 to 150 °C (0 to 302 °F) and conforming to requirements for Thermometer 1F in accordance with Specification **E1**.

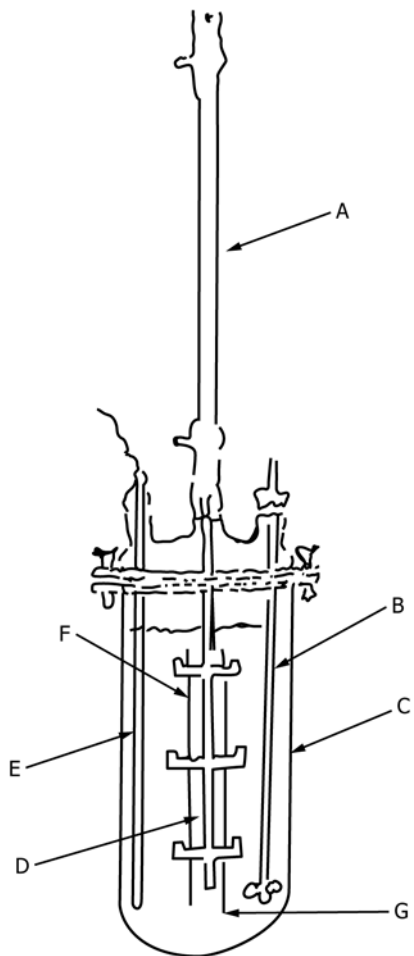

- A = Condenser
- B = Stirring mechanism
- C = Containing vessel
- D = Specimen holder
- E = Thermometer
- F = Metal specimen
- G = Maintenance chemical solution

NOTE 1—THIS IS ONE FORM THAT THE EQUIPMENT CAN TAKE, AND IS NOT MANDATORY. ANY ARRAY MEETING THE REQUIREMENTS OF 4.2 – 4.5 IS ACCEPTABLE.

FIG. 1 Test Apparatus

5. Reagents and Materials

5.1 *Mineral Spirits (Petroleum Spirits) (Hydrocarbon Dry Cleaning Solvent)*, conforming to Specification D235.

5.2 *Methyl n-propyl ketone (MPK)*.³

5.3 *Acetone*, conforming to Specification D329.

5.4 *Reagent Water*, conforming to Specification D1193.

6. Safety Precautions

6.1 The solvents used in the cleaning of test specimens are flammable and harmful if inhaled. Keep away from sparks and

³ The sole source of supply of Methyl n-Propyl Ketone (MPK) known to the committee at this time is Eastman Chemical Company, Kingsport, TN, USA. If you are aware of alternative suppliers, please provide this information to ASTM International Headquarters. Your comments will receive careful consideration at a meeting of the responsible technical committee,¹ which you may attend.

open flames. Avoid breathing vapors and prolonged or repeated contact with the skin. Use with adequate ventilation.

6.2 Flammable solvents, acids, or alkalis, or other toxic compounds are occasionally found in the material used for aircraft maintenance. Take suitable precautions to prevent personnel injury.

7. Test Specimens

7.1 The test specimens of a given alloy shall be taken from the same sheet stock and shall measure 50.8 by 25.4 by 1.6 mm (2 by 1 by 0.06 in.) with a 3.2-mm (0.125-in.) diameter mounting hole suitably located at one end of the specimen. Test at least two and preferably three replicates in each concentration of maintenance chemical solution in accordance with 9.2. The total area of the specimen shall be taken as 28.2 cm² (4.4 in.²).

8. Test Specimen

8.1 Preheat the test specimens to 60 ± 2 °C (150 ± 5 °F) and immerse in a beaker containing Mineral Spirits, Type II, conforming to Specification D235. Swab the surface of the individual specimen thoroughly using clean forceps to hold the specimen and the cotton swab.

8.2 Shake off the excess solvent. Transfer and immerse the test specimens separately several times in a beaker of methyl n-propyl ketone.

8.3 Shake off excess methyl n-propyl ketone and dry in a vacuum desiccator or in a low temperature oven at 37.7 ± 3 °C (100 ± 5 °F) for 15 min.

9. Conditioning

9.1 *Volume of Solution*—The volume of solution shall be 500 mL per specimen. Use fresh solution for each set of replicates.

9.2 *Solution Concentration:*

9.2.1 Unless otherwise specified, test the specimens in solutions of the maintenance chemical in the concentrated as-received condition and at the recommended dilution using distilled or deionized water conforming to Specification D1193, Type IV. (For solid materials, concentrated condition shall mean in a saturated solution of the solid material.) In case the material is not soluble to the extent noted, record this fact and continue with the test.

9.2.2 Test diphasic materials with an appropriate amount of each phase loaded into the test vessel to simulate use conditions. Totally immerse the corrosion specimens in the working phase of the maintenance chemical.

9.2.3 If water is not used as the diluent, record the type and specification of diluent used in the test.

9.3 *Temperature*—Unless otherwise specified, the temperature shall be 37.7 ± 3 °C (100 ± 2 °F).

9.4 *Test Duration*—Total test duration shall be 168 h, with specimens being added or removed at intermediate intervals.

9.5 If the maintenance chemical is to be used with agitation, also test the specimens with appropriate agitation to simulate use conditions.